



THE CHAMP Monthly Newsletter

of the Champlain Valley Chapter of ASHRAE

PRESIDENT'S MESSAGE



Snow, record rain fall and 40°F to Sunny and 90°F all within a weeks' time.. Only in VT! I guess the old saying my grandfather would always say: "if you don't like the weather in VT wait a

20 minutes" rings true.

Another CVC ASHRAE year is coming to a close and I can say that I've had a wonderful time serving as Chapter President. We've had some very engaging meetings, educational opportunities, and super fun social events. Our attendance at monthly meeting is strong at an average of 42 people, a whopping 33% of our membership. I'd say we've had a pretty successful year.

I'd like to thank Bill Cherry and Gretchen Langfeldt from Switchback Brewing for the hospitality at last month's Brewery Tour and Bill's presentation at our meeting. Switchback continues to be one of our biggest supporters, THANK YOU very much!

This year the CVC calendar is bookend by social events, we end the year with our Research Promotion fund raising Volleyball Tournament on June 5th. And like last year we start the year with our August 19th Golf

Tournament at Stowe country club. Look for sign-up details via email blast and all the info is in this addition of the newsletter and on our website, at www.ashraevt.org.

...continued on page 2

ASHRAE CVC UPCOMING EVENTS

August 15-17, 2013

2013 ASHRAE Region 1 Chapter Regional Conference - Burlington, VT August 15-17, 2013

August 19, 2013

ASHRAE CVC Annual Golf Tournament at Stowe country club, August 19th at 12:00 PM

contents

chapter reports

President's Message.....	1-2
Technology Transfer.....	2
Treasure's Report.....	3
Research Promotion.....	3
Meeting Calendar 2012-2013.....	4
Student Activities.....	5
Membership Promotion.....	5
Research Promotion Volleyball Tournament.....	6-9
2013 CRC Sponsorship Information.....	10
BOG Meeting Minutes.....	11-12
General Meeting MinuteS.....	13
EVT Partnership with CVC ASHRAE.....	14-19
CVC Chapter Visit March 11th, 2013.....	19
2013 ASHRAE CVC Golf Outing.....	20-23
ASHRAE Educational Training.....	24
2012 CRC Awards.....	25
2012-2013PresidentialNewsletter.....	25-26
POE.....	27
Chapter Contacts.....	27
Advertising/Sponsors.....	27-30

As you are probably aware, we are the host chapter of this year's Chapter Regional Conference, on August 15-17th at the Hilton in Burlington, VT. Tom Zoller and his planning committee have been hard at work planning this event for over a year. It's shaping up to be a great one with the presidential dinner at the Echo Center followed by Rusty the Logger as entertainment. The event includes a technical session on Thursday and a facility tour at UVM Aiken Hall on Friday at 2:30 pm. We would really like big support from our local chapter at these events as well as volunteers for the event itself. All the information for the event can be found at www.ashrae2013crc.com. Please contact nathanm@vhv.com to sign-up to volunteer.

In closing, it would like to thank you the membership for electing me and allowing me to serve as president of our great chapter. It was a pleasure and an honor.

- Tom Dacres

SAVE THE DATE: AUG 19TH

Monday August 19, 2013 @ 12:00 NOON - 2013 ASHRAE CVC Golf Outing at Stowe Country Club (Stowe, VT)



TECHNOLOGY TRANSFER

We have successfully made it to the end of another ASHRAE seasons and on behalf of the programs committee I would like to thank everyone!

Our final official meeting was a lot of fun. Once again the folks at Switchback invited us with open arms (and full glasses) for a most interesting tour of the new bottling line, while we were there they also showcased some of the improvements to the brewery they have made in the last year and gave us a taste of some things to come.

By now everyone should have seen the information come through their email about the volleyball tournament coming up the first week in June. This is a fun event intended to raise some money for research and promotion and we hope to see a lot of people there.

As the summer season is upon us and I make my transition from programs chair to chapter president I will be passing my torch to Rob Favali and over the next months the chapter meeting schedule and topics will start to take shape. If you are interested in presenting to the chapter next year, or if you have any ideas for chapter meeting topics please do not hesitate to get in touch with me, or with Rob. I can be contacted directly at nathanm@vhv.com

Thank you again to everyone who had a part in making this year successful. Get out there and enjoy the summer!

Think Spring
Nathan Mascolino

TREASURE'S REPORT

As of May 21, 2013 our TD Bank account is \$8,047.85 and all of our bills are paid up to date with our ASHRAE CVC account reconciled.

Our CRC-2013 Bank checking account is \$27,303.75 up slightly from April's numbers. All bills are paid and account reconciled for our ASHRAE CRC account.

At the end of our 2012-2013 year May31, 2013 we will be conducting our annual audit with the assistance of Jay Pilliod and Bill Atkinson. The final reports will be in our September's newsletter – starting off next year.

If at any time, anyone has any questions regarding our chapters financial status please don't hesitate to contact me.

Have a great summer.
Peter Bailey

RESEARCH PROMOTION

The upcoming volley ball tournament on June 5th will be our last fundraising opportunity for the 2012-2013 year and as you can see we have a long way to go to meet our goal. I hope to see you out there. I would like to personally thank all of those companies and individuals who have donated over the past year. We are very fortunate to have such active involvement from our membership.

2012-2013
Progress!!!

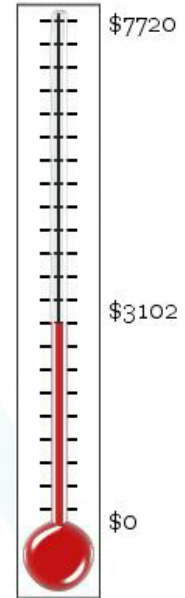

Thank you,
Rob Ward
RP Chair



Chuck Kabrehl

V.P. Commercial Sales & Engineering
ckabrehl@rjmurray.com

Dan O'Connor

Commercial Sales Engineering
doconnor@rjmurray.com

7 Northway Lane, Latham, NY 12110
79 Holly Court, Williston, VT 05495
518-690-4455 518-690-4990 (f)

Visit www.RJMurray.com for product info, what's new and employment opportunities.

2012-2013 ASHRAE CVC MEETING CALENDAR

JUNE 2013

Vol.27 No.09

September 5	October 3	November 7	December 5	January 9
<p>4:30 pm: BOG Meeting @ Hampton</p> <p>6:00 pm: Hydronic System Design & Boiler selection- Edward Sullivan (Weil McLain)</p> <p>7:00 pm: Dinner @ Hampton</p> <p>8:00 pm: Variable Speed pumping - Bill Reid Urell Inc</p>	<p>4:30 pm: BOG Meeting @ Hampton</p> <p>6:00 pm: Brattleboro Food co op - Andy Sapiro</p> <p>7:00 pm: Dinner @ Hampton</p> <p>8:00 pm: 2012 Fire & Building Safety Code - Bob Patterson</p>	<p>4:00 pm: BOG Meeting @ Hampton</p> <p>5:00 pm: Social Hour - Membership Promotion Night</p> <p>6:00 pm: ASHRAE CVC Business</p> <p>6:30 pm: Dinner @ Hampton</p> <p>7:15 pm: Richard Vehlow - Region 1 RVC MP Presentation</p> <p>7:30 pm: Natural Gas in VT. VT Gas future plan/ Fracking-Facts</p>	<p>4:00 pm: BOG Meeting @ Hampton</p> <p>5:00 pm: Social Hour - Holiday Mixer</p> <p>6:00 pm: ASHRAE CVC Business</p> <p>6:30 pm: Dinner @ Hampton</p> <p>7:30 pm: Sustainable Presentation Joint meeting with VGBN/ AIA</p>	<p>4:30 pm: BOG Meeting @ Hampton</p> <p>6:00 pm: Christopher M. McDonlad. IAQ & Mold: Legal Issues and Liability Concerns for Engineers & Related Industry Professionals</p> <p>7:00 pm: Dinner @ Hampton</p> <p>8:00 pm: ASHRAE Continuation of 6pm presentation</p>
February 6	March 6	April 3	May 1	Aug 15-17
<p>4:00 pm: BOG Meeting @ Hampton Inn</p> <p>5:00 pm: Social Hour Cash Bar</p> <p>5:45 pm: Buffet Dinner Served</p> <p>6:30 pm: Main Presentation- Dan Harris P.E. from the New Buildings</p>	<p>4:00 pm: BOG Meeting @ Hampton Inn</p> <p>5:00 pm, Social Hour and cocktails</p> <p>6:00 pm: VT State Rep. Robert Krebs, & Brad Aldrich, PE will present in favor of the NCEES Rule</p> <p>7:00 pm: Buffet Dinner Served</p> <p>8:00 pm: Jeffrey R. Mountain, PhD will give a presentation in opposition to the proposed NCEES rule</p>	<p>BOG Meeting - TBD</p> <p>Vermont Technical College - Red School House</p> <p>6:00 pm: Student Chapter Presentation on Winter Meeting Trip to Dallas, TX</p> <p>Large pellet boiler and hopper Tour @ Red School House VTC</p> <p>Student ASHRAE Design Competition submission(s) Buffet Dinner Served @ Red School House VTC</p>	<p>5:30 pm: Tour + BBQ + MP night</p> <p>Meeting Theme: Tour of the Switchback Brewery new bottling line.</p>	<p>ASHRAE Region 1 Chapter Regional Conference (CRC)</p> <p>Hilton Hotel</p> <p>Burlington, VT</p>

STUDENT ACTIVITIES

VTC Chapter

Committee Chair: Shawn LaBelle

Student Chapter Advisor: Chris Reilly

Student Chapter President: Kristen Gulrajani

I want to thank Professor Scott Sabol and the following students of Vermont Technical College for submitting their HVAC System Selection and HVAC Design Calculations for the ASHRAE Student Design competition:

HVAC System Selection

Jake Reed | Graduating May 2013

BS Architectural Engineering Technology

Patty Danahy | Graduating May 2013

BS Architectural Engineering Technology

Bailey Dimmick | Graduating May 2013

BS Architectural Engineering Technology

HVAC Design Calculations

Blaine Conner | Graduating May 2013

BS Architectural Engineering Technology

Greg Cadieux | Graduating May 2013

BS Architectural Engineering Technology

Matthew Molayem | Graduating May 2013

BS Architectural Engineering Technology

The submission will be evaluated by the Region 1 Student Activities Vice Chair by the deadline date of June 2nd. If they pass regional judging their entry will be submitted to the national judging committee for final judging on June 20th.

Thanks! - Shawn LaBelle

MEMBERSHIP PROMOTION

Hello Everyone,

I hope this newsletter finds you gearing up for summer which is right around the corner. I want to thank everyone who came out to the meeting last month at Switchback. We had a great turnout. I would like to think it was because of it being a Membership Promotion Night, but we all know it was simply because of the great beer Switchback has to offer. Congratulations to Mike Vanhorn on winning the raffle for a case of Switchback's newly bottled Ale. I hope everyone enjoyed themselves. Thanks for the support.

The year is wrapping up for Membership Promotion. I would like to take this opportunity to say thanks to everyone who helped grow our great chapter this past year. We currently have a total of 10 new members who signed up, along with 3 new Student Members. In such a small chapter, and a close knit industry community, these results are fantastic. I will be continuing on next year as our Membership Promotion Chair and hope to outperform our last year's success. Please continue to spread the word about our great Champlain Valley Chapter amongst your peers and encourage them to attend some of our upcoming meetings. Always remember, we cannot be successful without the help of all of you.

As always, thanks for all the help and support to grow our great chapter. Enjoy!

Josh Chiappone
Membership Promotion Chair

Leadership Quote of the Month

"When you want to know how things really work, study them when they're coming apart."

~ William Gibson

SUMMER RP EVENT VOLLEYBALL TOURNAMENT / BBQ

Well after another successful chapter summer outing and BBQ we have managed to raise \$2,540 for research promotion. This last infusion of money allowed us to make our minimum goal for the year and got us that much closer to our High Five goal.

I would like to thank all of the companies and individuals who donated their time and money to make this thing happen on relatively short notice. Tom Dacres came up with the original idea to bring the tournament back. Rachael Mascolino secured the location. Nathan Mascolino found a tournament bracket that worked with an odd number of participants. He was also the official for the event and kept the games on schedule. Cara our webmaster took pictures of the days events. Jason Hudspath and Joe Kazukenus from Thermal Environmental Sale donated all the drinks and manned the beverage station. As usual Phil Bresnahan and Jim Lavallee from Vermont Mechanical (The Grillers in the Mist) did not disappoint. They did all the shopping and amazing cooking. The food was paid for by Josh Chiappone and Johnson Controls.

The event was very well attended and from what I saw everyone had a great time. At the end of the day it was Alliance Mechanical that brought home the trophy and owns the bragging rights until the next tournament. The final results went as follows:

- 1 - Alliance
- 2 - Control Technologies
- 3 - Efficiency Vermont
- 4 - Vt Gas / Dodge Engineering
- 5 - VHV



Below is the balance sheet:

Team	Captian	Money In	Money Out	net Profit
Alliance Mechanical	Shawn LaBelle	\$ 500.00	\$ -	\$ 500.00
VHV	Rob Ward	\$ 530.00	\$ -	\$ 530.00
EVT	RM	\$ 300.00	\$ -	\$ 300.00
VT Gas / Dodge Engineering	Peter Bailey	\$ 500.00	\$ -	\$ 500.00
Control Tech	Randy Mead	\$ 500.00	\$ -	\$ 500.00
EVT & individuals		\$ 260.00	\$ -	\$ 260.00
Food- JCI		\$ 609.49	\$ -	\$ 609.49
Food reimbursement			\$ 609.49	\$ (609.49)
Pavilion rental			\$ 50.00	
Keg, Water, Soft Drinks		\$ -	\$ -	
Totals		\$ 3,199.49	\$ 659.49	\$ 2,540.00





VOLLEYBALL TOURNAMENT RESULTS

Winner's Bracket

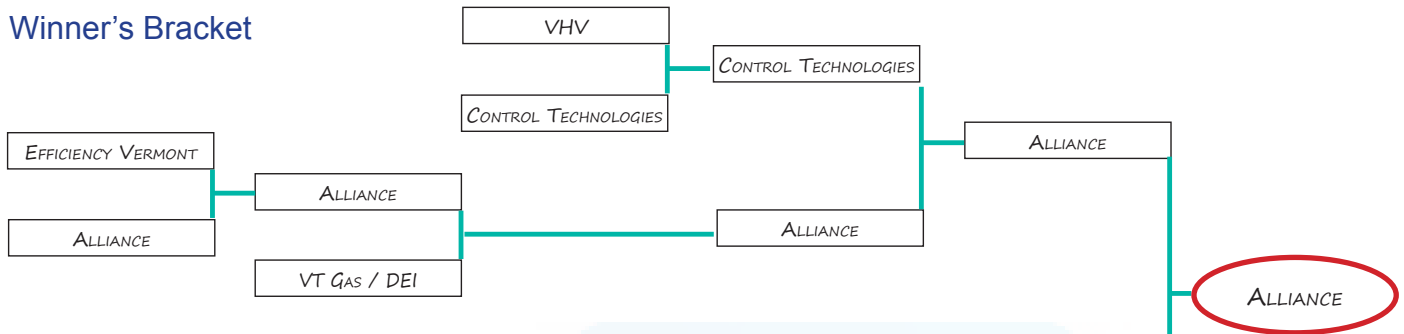

Loser's Bracket

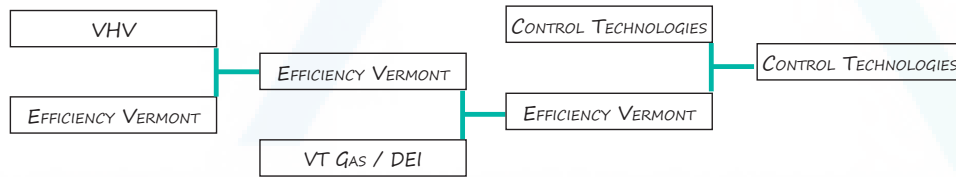

2013 VOLLEYBALL TOURNAMENT CHAMPIONS - ALLIANCE





Thank you to the following companies for their generous sponsorship of the upcoming Region 1 Chapter Regional Conference – August 15-17, 2013 Burlington, VT

Platinum Level (\$5,000 minimum)



Gold Level (\$2,500 minimum)



Silver Level (\$500 minimum)

Vermont Heating and Ventilating
Multistack
Vermont Mechanical
F.W. Webb
Blake Group
Dubois and King, Inc.
Viega

Quality Air Control
Daikin AC
L.J. Early
Yeaton Associates
Hallam-ICS
Acme Engineering Prod. Inc
Vermont Gas Systems

Bronze Level (\$150 Minimum)

R.F. Peck
ARC Mechanical
Advanced Comfort Systems

Control Technologies
R.J. Murray
Dodge Engineering and Controls

Vermont Product Partners



2012-2013 Board of Governors



BOG MEETING MINUTES

May, 2013 BOG Meeting Minutes

Date: 05/09/2013

Location: Vermont Heating & Ventilating, Winooski VT

Time Called to Order: 12:08pm

Called to Order By: Tom Dacres

Minutes Recorded By: Rob Ward

ATTENDANTS

Tom Dacres	VHV
Rob Favali	Dubois & King
Shawn Labelle	Alliance Mechanical
Dick Wilcox	VHV
Rachael Mascolino	Efficiency Vermont
Peter Bailey	Dodge Engineering & Controls
Mike Cook	ARC Mechanical
Rob Ward	VHV
Tom Zoller	Trane
Joshua Chiappone	Johnson Controls
Nathan Mascolino	VHV

LAST MEETING MINUTES

A motion was made by Rachael M. to approve April 2013 Meeting Minutes. It was seconded by Nathan M. and the motion was carried.

OFFICER REPORTS

A.) PRESIDENT: TOM DACRES

a) Tom is working on completing the documents required for the ASHRAE State registration.

b) Tom is looking for volunteers to help with the CRC.

c) Tom gave an update of where we are at with PAOE Points

d) Newsletters articles are due by 05/20/13.

e) Tom stated that it may be too late to pursue this Presidential theme project for this year. Rob Favali said that he would provide a person to do the survey of the existing building.

f) The results are in from the online voting. Cody Lezak has been chosen to be the Chapter Secretary for the 2013-14. The new officers and board members will be installed in September.

g) Shawn Labelle asked for volunteers to review and score the VTC student design competition. He briefly went over how the scoring worked. Shawn and Mike Cook will be doing the scoring.

h) Nathan M. made a motion to spend an amount not to exceed \$500 to cover hotel expenses for Josh C. to attend Membership Promotion training in Denver on June 23rd. The motion was seconded by Rob Favali. It was put to a vote and passed.

i) Tom stated that all committee chairs needed to be filled and CIQ completed by June 1st. Shawn Labelle agreed to stay on as liaison to the student chapter. Dick Wilcox has agreed to take on the new position of Government Grassroots Committee chair.

j) Tom is looking for candidates for the yearly financial audit. A couple of names that were mentioned were Bill Atkenson and Jay Pilliod.

k) There is a preplanning meeting scheduled for July. Nathan M. to provide details on time and

location at a later date.

l) Tom is planning touch base with Ray Hickey and John Grout to get an update on the summer golf outing.

m) Peter stated that all but one website / newsletter add had been paid for for this year.

n) Tom and Nathan spoke with the ASHRAE representative in D.C. and he recommended that they draft a letter to our lawmakers that reflect our chapter's stance on the "M.O.E." issue.

o) There was a brief discussion on where and when to hold the volleyball fundraiser. Rachael stated that she had not yet heard back from the person in charge of the Williston facility.

**B.) PRESIDENT ELECT:
NATHAN MASCOLINO – CTTC CHAIR**

a) Nothing new to report.

C.) VICE PRESIDENT: ROB FAVALI

a) Nothing new to report

D.) TREASURER – PETER BAILEY

a) Nothing new to report

**E.) CHAPTER SECRETARY: ROB WARD –
RESEARCH PROMOTION CHAIR**

a) There was as short discussion on fundraising ideas. It was decided that a volleyball tournament would be a great idea. Tom D. is the keeper of the old Volleyball plaque and he plans to offer it to the winner.

F.) HISTORY: MIKE COOK

a) Mike stated that he is finished with his Gold Ribbon submission and is waiting on some updated photos of the subjects.

G.) REFRIGERATION: PETER BAILEY

a) Cody Lezak agree to be a member of this committee.

b) Peter stated that he will be working on the chapter website this summer.

**H.) ELECTRONICS COMMUNICATION CHAIR:
RACHAEL MASCOLINO**

a) Nothing new to report.

**I.) MEMBERSHIP PROMOTION CHAIR:
JOSHUA CHIAPPONE**

a) Membership promotion night will follow the BOG meeting with a tour at Switchback Brewery.

J.) STUDENT ACTIVITIES – SHAWN LABELLE

a) Shawn stated that he will be submitting Chris Reilly as the Student Branch Advisor of the Year.

**K.) YEA COMMITTEE: SHAWN L., RACHAEL
M., JOSH C.**

a) Nothing new to report

OLD BUSINESS:

None

NEW BUSINESS:

None

MEETING ADJOURNED

A motion was made by Nathan Mascolino to adjourn the meeting. It was seconded by Rob Favoli and the motion was carried. The meeting adjourned @ 5:10 PM.

These minutes are the writers understanding of the discussions involved. If there are any exceptions taken, or omissions, please notify the writer immediately.

GENERAL MEETING

May 9, 2013 General Meeting Minutes

Date: 05/09/13

Location: Switchback Brewery

Minutes Recorded By: Rob Ward, Secretary

ATTENDANTS

Tom Dacres	Vermont Heating & Ventilating
Peter Bailey	Dodge Engineering & Controls, Inc.
Harris Unger	Advanced Comfort Systems
Rob Favali	DuBois & King Inc.
Rachael Mascolino	VEIC, Efficiency Vermont
Nathan Mascolino	Vermont Heating & Ventilating
Rob Ward	Vermont Heating & Ventilating
Michael VanHorn	Control Technologies
Howard Merson	Efficiency Vermont
Jason Hudspath	Thermal Environmental Sales
Robert Stephenson	Vermont Energy Investment Corporation
Ray Spear	Trane
Tom Zoller	Trane
Joseph Kazukenus	Thermal Environment Sales
Matt Dooley	VEIC
Jay Pilliod	Efficiency Vermont
John Lincoln	Burlington Electric Department
Scott Harrington	Vermont Gas
Jared Kershaw	Vermont Heating & Ventilating
Jesse Robbins	Freeman French Freeman
Charles Vermonneau	Control Technologies
Cody Lezak	Efficiency Vermont
Gretchen Langfeldt	Switchback Brewing
Paul Gustafson	
Ray Hickey	Advanced Comfort Systems
Richard Travers	Freeaire Refrigeration
Dave Robistow	Vermont Heating & Ventilating
Allen Myers	Vermont Heating & Ventilating

Scott Alexander	LN Consulting
Josh Chiappone	Johnson Controls
Michael Cook	ARC
Bill Gregory	L.J.Early Co.
Trevor Gensch	Daikin AC
Martha Soule Holden	Vermont Heating & Ventilating
Chris Vintner	Control Technologies
Charles Carpenter	VEIC
John Johnston	Breadloaf
Bill Chevy	Switchback Brewing

The meeting started with a tour of the Switchback Brewing Company's new bottling line. Gretchen Langfeldt was the guide and explained the process and the duties of all the equipment involved.

The tour was followed by a dinner at the Hampton Inn, Colchester.

After dinner was a presentation by the owner of Switchback Brewing Company on the history of the company and the beer they produce. He also opened the floor up to any questions that attendees had.

These minutes are the writers understanding of the discussions involved. If there are any exceptions taken, or omissions, please notify the writer immediately.



Efficiency Vermont Mission Creates Mutually Beneficial Partnership with CVC ASHRAE



By Michael R. Cook – Chapter Historian

This article is a compilation of information gathered from a radio interview with Beth Sachs and Scudder Parker on Feb 27, 2013 on Vermont Conversation with David Goodman aired on our local Vermont Public Radio station. It also contains responses from an email questionnaire with Jay Pilliod of Efficiency Vermont, CVC chapter documents and the Efficiency Vermont and ASHRAE websites.

THE ORGANIZATION

In 1999 the Vermont legislature passed a law enabling the creation of Efficiency Vermont. In 2000 Efficiency Vermont started delivering energy efficiency services to help Vermonter's save energy, reduce their energy costs and protect Vermont's environment. Prior to this legislation each of Vermont's public utilities provided their own efficiency programs and services under demand side management initiatives.

By establishing Efficiency Vermont it enabled all Vermonter's to receive a consistent and comprehensive set of services from a single provider. The only exception to this consolidated approach in the state is the city of Burlington, Vermont's largest city continues to manage and operate its own energy efficiency programs through the Burlington Electric Department.

Efficiency Vermont (EVT) is the statewide energy efficiency utility in the state of Vermont. The Vermont Energy Investment Corporation (VEIC), a mission driven, non-profit organization, administers Efficiency Vermont under an order of appointment from the Vermont Public Service Board. Founders of VEIC Beth Sachs and the late Blair Hamilton founded VEIC in 1986 with a desire to lessen the economic and environmental impact of energy use. Efficiency Vermont was the nation's first energy efficiency utility providing technical assistance and financial incentives to help Vermont homeowners and businesses reduce their energy use and energy costs by encouraging energy efficient buildings, equipment and lighting. The organization provides technical assistance for evaluating efficiency alternatives, information about available financial incentives and collaborates with industry organizations, building design and construction professionals to promote the use of new technologies and techniques and sharing knowledge and experiences gained on implemented projects.

Efficiency Vermont has been a major contributor to the energy efficiency field in Vermont and very supportive of the ASHRAE Champlain Valley Chapter activities through sponsorship of chapter seminars and events, Efficiency Vermont staff attending monthly meetings and supporting many of their staff who have served as committee chairs and officers. VEIC through Efficiency Vermont has lead Vermont and other states (Rhode Island, Pennsylvania, New Jersey, Maryland ,and Ohio) and municipalities (Washington DC) as a technical resource on energy efficiency options giving unbiased objective advice, and using creative and innovative financing instruments to help provide capital for energy efficiency investments for residential and business

owners. Their organizational mission dovetails very well with the mission and goals of ASHRAE.

INVOLVEMENT WITH ASHRAE CVC

When I was considering putting together this article I learned early on during an initial discussion with Amy Patenaude (a current EVT employee) that to understand how Efficiency Vermont came to be a presence and supporter of our chapter activities that the person I needed to contact was Jay Pilliod. Jay joined the Champlain Valley Chapter in 2000 and he immediately became involved with chapter operations and served in several committee chair and officer positions and served as 2006-2007 Chapter President.

To explore the history and motivating circumstances of the initial involvement of Efficiency Vermont in the Champlain Valley Chapter I conducted an interview with Jay which follows:

1. Since your initial involvement with ASHRAE, Efficiency Vermont has been very supportive and involved in the local ASHRAE CVC chapter, was there a business goal or mission which drove this relationship?

One of the key goals of Efficiency Vermont is to work closely in partnership with the design and construction community to increase knowledge of energy efficiency opportunities and encourage sustainable solutions. ASHRAE's mission is "to advance the arts and sciences of heating, ventilating, air conditioning and refrigerating to serve humanity and promote a sustainable world", so there is a clear link between our missions and opportunity for partnership. The local chapter of ASHRAE is an excellent educational and outreach forum and clearly one that we wanted to help support.

2. What benefits or knowledge gained from ASHRAE involvement did Efficiency Vermont envision to promote its own mission/goals?

The technical seminars and tours that are part of each monthly meeting are a great resource for keeping the membership, as well as our staff, informed of new technologies and advances in the HVAC&R field. Lots of valuable "lessons learned" and better understanding what works – or doesn't work – is great. We also benefit from the networking opportunities to discuss current and future projects and how we might support increasing the efficiency of those projects.

3. Do you think the ASHRAE/EVT relationship has been successful towards meeting EVT's goals/mission?

Absolutely. From my perspective the relationship between CVC ASHRAE and Efficiency Vermont has been mutually beneficial and exceeded my expectations in terms of how a partnership such as this can be successful.

4. EVT's participation has been more than staff attendance at meetings many have become active in chapter operations with a number of EVT staff serving as chapter officers. Does this reflect an Efficiency Vermont goal for staff (i.e. professional development and leadership growth) supported within EVT or is it just their individual choice to advance personal achievement?

Over the past decade, Efficiency Vermont has had several staff participate as chapter officers, committee chairs, or members of the Board of Governors (or all the above) which has offered a great learning and professional development opportunity in leadership, management, and public speaking. I certainly learned a lot in the various positions that I served over the years. Efficiency Vermont encourages and supports this involvement for those interested in pursuing this path.

5. Based on your experience and involvement with ASHRAE, what function or benefits does ASHRAE provide to the energy efficiency sector? In your opinion does current ASHRAE standards development and research continue to advance the field of energy efficiency? Any thoughts where future ASHRAE involvement/initiatives would be beneficial?

ASHRAE has a long history promoting energy efficiency since it first published Standard 90.1 in 1975 through to the most recent publications of the Advanced Energy Design Guide series which provide guidance on how to achieve buildings that use 30-50% less energy than meeting code. Four of these design guides are now available from ASHRAE that include Small to Medium Office Buildings, k-12 School Buildings, Medium to Big Box Retail, and Large Hospitals (free for download from www.ashrae.org). I hope that ASHRAE continues to invest in these types of guides that encourage the industry to lead by example by ensuring buildings are designed and built to the highest possible efficiency levels to minimize their long-term operating costs and environmental impact.

6. What role do you think equipment technology, alternative energy, green building or public education will play in guiding energy efficiency policy in the future?

All these already are playing a very significant role in guiding energy policy currently and this is likely to only increase dramatically in the near future as the concerns over climate change and rising energy costs continue to grow.

7. In your opinion what shared values, goals, or missions by both ASHRAE and EVT support accomplishing societal objectives of energy efficiency and conservation?

ASHRAE and Efficiency Vermont are both committed to promoting a sustainable world which given the current environmental crisis facing the planet due to climate change is both critical and urgent for our organizations to do everything we can to help address. Working in partnership will allow us to achieve greater success toward this goal.

8. What are some of the future goals or missions of EVT as a leader in the energy efficiency field?

To address the growing need for better financing mechanisms to help building owners make investments in efficiency that often result in a positive cash flow but require upfront capital to make happen. The increasing availability of utility usage data through “smart” meters and simple analysis tools allows customers to better understand and manage their energy usage. Efficiency Vermont’s goal is to support customers in using this data to better inform efficiency improvement decisions.

9. Commentary: What have you personally learned or gained through your participation and experiences as an officer in the ASHRAE CVC chapter.

Working my way through the various officer positions in the CVC Chapter allowed me to gain a better insight into the various focus areas that ASHRAE is involved in and appreciate the huge amount work that goes into running a volunteer-based chapter. Keeping track of all the various committees and ensuring work toward meeting all their goals and deadlines offered a unique management challenge for me and I learned a lot. Fortunately, the CVC Chapter has always had a great group of folks leading this effort with lots of experience and skills which made the experience both manageable and fun. I really appreciate the team approach to running the chapter successfully each year.

CHAPTER OPERATIONS PARTICIPATION OF EFFICIENCY VERMONT EMPLOYEES

Jay Pilliod joined the Champlain Valley Chapter in 2000 and he immediately became involved with chapter operations and served in several positions including Committee Chair of TEGA, Membership and Technology Transfer. He has held the elected positions of Vice President, President Elect culminating in his term as 2006-2007 Chapter President.

Amy (Cota) Patenaude, P.E. holds the historical distinction of being one of the founding members of the ASHRAE VTC Student Chapter in 1996 and becoming involved in the operations of the Champlain Valley Chapter in 1996 as Newsletter Editor. She has held the committee chair positions of Membership, Student Activities, Programs and History. Amy has served all elected officer positions of the chapter except Treasurer culminating in her term as 2002-2003 President. Additionally she served as member and 2010-2011 Chair of the Society Electronic Communications Committee.

Heather (Condon) Smith joined ASHRAE and the Champlain Valley Chapter in 2002. She became involved in chapter operations in 2005 as Secretary. She has held the Committee Chair positions in Membership Promotion, Technology Transfer and Research Promotion as well as Newsletter Editor. Heather held the elected positions of Vice President, President Elect culminating in her term as Chapter president in 2008-2009.

Mary Jayne Poynter – Served two terms as Chapter Secretary 2003-2005.

Sandy LaFlamme – Served as Research Promotion Chair 2010-2011 winning a Region 1 Outstanding

Performance Research Promotion Honorable Mention Award.

Rachael Mascolino – Became a new member of the CVC BOG in 2011-2012 and currently serves on BOG and is Electronics Communication Chair for 2012-2013.

BETTER BUILDINGS BY DESIGN CONFERENCE HOST



For several years Efficiency Vermont has organized and operated the annual Better Buildings by Design Conference held at the Sheraton Inn in South Burlington in February which is attended by more than 1,000 builders, architects, engineers, other design professionals and contractors. The two day conference provides exposure to new ideas and information on the latest energy efficiency technologies, techniques and applications that attendees can apply this new knowledge to their current and future projects. To reward design and building professionals for their great work and dedication throughout the year and recognize innovative and integrated design approaches for energy efficiency in Vermont's institutional, industrial, multifamily and residential buildings, the Efficiency Vermont Awards recognize the "Best of The Best" in several categories and subcategories including but not limited to Commercial & Multifamily, Energy Efficient Residential New Construction and Home Performance with Energy Star as examples. The projects of the award winners are prominently displayed throughout the conference meeting areas.

JUNE 2013

Vol. 27 No. 09



The conference presents over 35 concurrent workshops focused on many interest tracks such as building envelope, mechanical systems, lighting and innovations and high performance each promoting benefits of building durability, superior performance, energy efficiency and economic value for a variety of residential and commercial projects as well as emerging trends. Many of the workshop presenters are nationally renowned and have included many ASHRAE Distinguished Lecturers. In addition Efficiency Vermont provides educational credits for organizations like AIA, BPI or NATE. Attendees requiring CEU credits for non-participating organizations can fill out continuation credit request forms available at the conference for self reporting. Another part of the conference is a product exhibition allowing 50 or more exhibitors to set up booths showcasing energy efficiency products and services.

CONCLUSION

As you can see these two non-profit organizations, ASHRAE and Vermont Energy Investment Corporation through Efficiency Vermont share a common mission and commitment to encourage energy efficiency in today's building industry and to promote sustainability principles. Sustainability means to create a safe, healthy, comfortable indoor environment while simultaneously limiting the impact on the Earth's natural resources. Like Efficiency Vermont, ASHRAE is a leader within the energy efficiency industry with its mission of being the foremost source for industry standards, technical resources and educational information for the building design profession.

Both organizations share common values:

Excellence reflected in the application of best practices to lead our industry in sustainable design and energy efficient buildings and striving for continuous improvement and innovation.

Collaboration – by seeking out and embracing collaborative efforts with other organizations and agencies committed to a sustainable built environment.

A dedicated **Commitment** in the application of energy efficiency technologies, techniques and methods to create value thru energy savings for our customers and recognizing the accomplishments of others by the membership of ASHRAE and staff of Efficiency Vermont.

The dedicated professionals of ASHRAE and Efficiency Vermont are working proudly to shape tomorrow's built environment today by focusing on energy efficient building systems, renewable and alternate energy

Chapter Visit- Champlain Valley Chapter, March 11th, 2013

Joe, Spencer and Tom,

I apologize for getting this report out almost three months after the meeting, but i do want to thank you, Tom, and the chapter for your hospitality and for a great meeting. My report follows.

Champlain valley chapter has the majority of its monthly meetings in the Hampton Inn Hotel in Colchester, just north of Burlington. The meeting i attended was on the evening of Monday, March 11. Meetings are normally the first Wednesday of the month, but a change in the date was necessary to accomodate the two presenters.

I arrived in time to check in and go to the 4pm BOG meeting. It appears that the chapter is enjoying a good year overall. This chapter will be hosting the CRC this August, and continue to make substantial preparations, and discussions of the CRC comprised the main focus of the meeting.

The general meeting was held in a small room in the hotel and there were about 35 people present. One of those in attendance was a member who was also a past president of the National Society of Professional Engineers. The registration for this and all meetings are done online on the chapter's website, instead of by email and/or phone.

A cocktail hour preceded the dinner. In addition to the fellowship, a tabletop presenter from Weil-McLain was on hand to answer questions about hydronic boilers. Dinner was a delicious buffet. Following dinner, I was invited to say a few brief words to the chapter in my capacity as membership promotion chair but I also took the opportunity to speak regarding the role of grassroots Government Activities RVC, which I will roll into on July 1. I am unsure how many new members and YEA members were present in the audience.

The technical topic was unlike anything I had ever seen before at an ASHRAE meeting, yet was extremely appropriate and fitting to me as the incoming GGAC RVC. There were two speakers, each with an hour to present (one before and one after dinner) each side of a debate on the future of professional engineering licensure. The first speaker, Brad Aldrich PE, spoke in favor of the proposed NCEES guidelines for a Masters degree or equivalent (30 credit hours of post-baccalaureate education) in order to qualify to sit for the PE licensure exam. The second speaker was Dr. Jeffrey Mountain of Vermont Technical College, who spoke in favor of the status quo for many states- no post-baccalaureate requirement to sit for the exam, but 30+ PDH hours every three years to renew.

Normally the quiet one in a meeting, this was easily the meeting in my 15 years in ASHRAE where I asked the most questions from the audience than at anytime else. The rest of the room weighed in heavily on the debate as well. The strong- possibly unanimous- consensus in the room preferred the status quo over the NCEES proposal for the following reasons: extra time and expense to get a masters degree, the value of learning on the job vs. the classroom, classroom education may not necessarily mirror actual projects undertaken during career, classroom education at the front end of your career will become outdated, continuing PDH courses remain up to date, and I am sure several other opinions I have missed. In short, these are the issues that will face me as GGAC RVC over the next four years, hence I couldn't have attended a more appropriate and preparatory meeting as this one!

Following the meeting, I roomed for the night upstairs in the Hampton Inn, and returned to Troy the following morning.

Again, I thoroughly enjoyed my visit. Thank you for the opportunity to attend this unique and pertinent meeting, and for your hospitality. I am looking forward to returning to Burlington for a great CRC in August!

Sincerely,
Richard Vehlow
RVC MP



CHAMPLAIN VALLEY CHAPTER of ASHRAE

2013 ASHRAE CVC Golf Outing

Stowe Country Club (Stowe, VT)

Monday August 19, 2013 @ 12:00 NOON

Schedule:

Registration starts at 12:00 NOON, Shotgun start at 1:00 PM, box Lunch, and during the awards... finger food after golf.

Tournament Costs:

Foursome package includes, golf and food ... \$400 per foursome, 18 holes with cart, sleeve of balls, raffle ticket, fun with friends, and support of the CVC ASHRAE Research & Promotion

Tournament Format:

Standard "Captain and Crew"

Prizes: Vendors are encouraged to participate in the raffle prizes

Prizes for low team score, longest drive, putting contest, and closest to the pin

Vendor and Chapter raffle prizes

Tee Flags: Available to vendors, mechanical contractors, engineering firms, individual... Still.....\$100 EACH!

Special Thanks to our last year sponsors:

Advanced Comfort Systems, Scott A. Sabol PE, Trane Company, Buckley Associates, Vermont Heating & Ventilating, Hallam-ICS, Vermont Mechanical Inc., Victaulic, F.W. Webb, Thermal Environmental Sales, Johnson Controls Inc., R.L. Kistler, Control Technologies Inc., Mitsubishi HVAC, Trojan Energy, Shannon Insultech Technology Plus), MultiStack (Trane), Efficiency Vermont, Dubois & King, R.F. Peck, L.J. Early, ARC Mechanical

CHAMPLAIN VALLEY CHAPTER of ASHRAE

ASHRAE CVC Golf Outing

Stowe Country Club (Stowe, VT)

Monday August 19, 2013 @ 12:00 Noon Registration

CVC ASHRAE "RULES"

1. All USGA and golf etiquette rules will be followed.
2. Stowe Country Club rules are to be followed.
3. Teams consist of four (4) players unless there is less.
4. If there are less than four (4) players, team members must alternate in order to hit the fourth shot.
5. Standard "Captain and Crew" Format
6. Mulligan's, if purchased, allows each team member to use their mulligan at any time, but they must wait until all other team members have hit their shot. Team members get one (1) mulligan for the round.
7. Your mulligan **can not** be used when putting on the green's surface.
8. Teams are allowed to position the ball one (1) club length from your team's ball of choice, but not any closer to the hole. However, if the ball is in a hazard it cannot be moved out of the hazard. IE bunker...
9. Male players must play from the WHITE tees and Female players from the RED tees.

50/50 Putting Contest

1. Each participant will get one chance at the cost of \$10 (Monies go to Research and Promotion).
2. Participant must start from the location determined by the "observer".
3. Target hole will be 20 feet away.
4. The ball must go in the designated hole in order to count.
5. We expect several players to make the putt.
6. A playoff will take place before the awards ceremony.

CVC ASHRAE 2013 GOLF OUTING REGISTRATION/ SPONSORSHIP FORM

Monday August 19th, 2013 12:00 NOON Registration at Stowe Country Club

744 Cape Cod Road Stowe, VT 05672 www.stowecountryclub.com

TEAM NAME: _____

GOLF PACKAGE: Four golfers, 1 each raffle ticket, sleeve of balls, cart, food.

HOLE SPONSORSHIP: Tee-flag with your company's name placed prominently of the tee-boxes

ITEM	QUANTITY	COST	EXTENDED COST
TEAM OF GOLFERS	()	\$400 per team	()
HOLE SPONSORSHIP	()	\$100 per hole	()
MULLIGANS (four, one per each player)	()	\$25	()
TOTAL			()

PLEASE CONSIDER THE CONTRIBUTION OF A RAFFLE GIFT (Gift Certificate)

Donations will be acknowledged during awards ceremony

PLEASE RESPOND VIA EMAIL, MAIL, or FAX NO LATER THAN JULY 20, 2012

PLEASE SEND FORMS TO RAY HICKEY rhickey@advancedcomfortsys.com

518-884-8411 Fax 518-701-4086 Cell

MAIL: Ray Hickey 12B Commerce Drive Ballston Spa, NY 12020

TEAM MEMBER NAME

Golfer #1 _____

Golfer #2 _____

Golfer #3 _____

Golfer #4 _____

QUESTIONS????? John Grout 508-878-9155 or email jgrout@victaulic.com

ASHRAE Learning Institute 2013 Spring Online Course Series

2 WAYS TO REGISTER

Internet: www.ashrae.org/dallascourses

Phone: Call toll-free at 1-800-527-4723 (US and Canada) or 404-636-8400 (worldwide)

Note: You may register up to 24 hours prior to an online course. Courses are in US Eastern Standard Time.



Basics of High-Performance Building Design

Mon, March 18, 2013 – 1:00 pm to 4:00 pm EDT

Instructor: Tom Lawrence, Ph.D., P.E., Member ASHRAE, LEED® AP

Air-to-Air Energy Recovery Fundamentals

Wed, March 20, 2013 – 1:00 pm to 4:00 pm EDT

Instructor: Paul Pieper, P.Eng., Member ASHRAE

Advanced High-Performance Buildings Design

Mon, March 25, 2013 – 1:00 pm to 4:00 pm EDT

Instructor: Jeff Ross-Bain, P.E., Member ASHRAE

Air-to-Air Energy Recovery Applications: Best Practices

Wed, March 27, 2013 – 1:00 pm to 4:00 pm EDT

Instructor: Paul Pieper, P.Eng., Member ASHRAE

Complying with Standard 90.1-2010: Envelope/Lighting

Wed, April 17, 2013 – 1:00 pm to 4:00 pm EDT

Instructor: Joe Deringer, AIA, Member ASHRAE, LEED® AP



Humidity Control Troubleshooting

Mon, April 22, 2013 – 1:00 pm to 4:00 pm EDT

Instructor: Lew Harriman, Fellow ASHRAE

Combined Heat & Power: Creating Efficiency Through Design & Operations

Wed, April 24, 2013 – 1:00 pm to 4:00 pm EDT

Instructor: Lucas Hyman, P.E., Member ASHRAE, LEED® AP

Complying with Standard 90.1-2010: HVAC/Mechanical

Mon, April 29, 2012 – 1:00 pm to 4:00 pm EDT

Instructor: Mack Wallace, P.E., Member ASHRAE, LEED® AP

The Commissioning Process & Guideline 0

Wed, May 1, 2013 – 1:00 pm to 4:00 pm EDT

Instructor: Walter Grondzik, P.E., Fellow/Life Member ASHRAE, LEED® AP

Fundamental Requirements of Standard 62.1-2010

Wed, April 17, 2013 – 1:00 pm to 4:00 pm EDT

Instructor: Hoy Bohanon, P.E., Member ASHRAE, BEAP, LEED® AP

Take 3 or more courses and save 20% off registrations!

Register at www.ashrae.org/onlinecourses

Site Licenses are available for 5 or more registrants!

HVAC Design Training

Mar 18-22, 2013 • Jun 3-7, 2013 • Aug 12-16, 2013

HVAC Design: Level I - Essentials

This training provides intensive, practical education for designers and others involved in delivery of HVAC services. Gain practical skills and knowledge in designing, installing and maintaining HVAC systems that can be put to immediate use. The training provides real-world examples of HVAC systems, including calculations of heating and cooling loads, ventilation and diffuser selection using the newly renovated ASHRAE Headquarters building as a living lab.

Registration is \$1239, \$989 (ASHRAE Member)

Enroll 3 or more participants from the same company and save!



HVAC Design: Level II - Applications

Developed by industry-leading professionals, the workshop provides participants with advanced level information about designing, installing and maintaining HVAC systems that can be put to immediate use. Participants will gain an in-depth look into Standards 55, 62.1, 90.1, and 189.1 and the Advanced Energy Design Guides, as well as a range of other HVAC topics including: HVAC equipment and systems; energy modeling; designing mechanical spaces; designing a chiller plant; and BAS controls.

Registration is \$829, \$679 (ASHRAE Member)

Enroll 3 or more participants from the same company and save!

Visit www.ashrae.org/hvacdesign to register

2012 CRC AWARDS

Here are the (7) awards the Champlain Valley Chapter received at the 2012 CRC in Boston on August 25, 2012 during the awards luncheon.

- ▶ Champlain Valley Research Promotion – Rob Ward -Full Circle, Goal, High Five, Challenge
- ▶ Champlain Valley PAOE Awards – Honor Roll, Star, Special Citation – Michael R. Cook
President
- ▶ 2011-2012 ASHRAE Region 1 CTTC -Award of Excellence – Tom Dacres
- ▶ 2011-2012 ASHRAE Region 1 Black Ink Award “The Champ” – Cara Gorman
- ▶ 2011-2012 ASHRAE Region 1 Websitation of Excellence – Cara Gorman and Rachael Mascolino
- ▶ 2011-2012 Certificate – Participation in Student Design Competition, HVAC Design – Shawn LaBelle and VTC Student Chapter
- ▶ 2010-2011 ASHRAE Region 1 CTTC PAOE Sustainability Award – Michael R. Cook

2012-2013 PRESIDENTIAL NEWSLETTER

DATE: April 12, 2012

TO: Chapter Presidents
ASHRAE Membership Promotion Committee
ASHRAE Student Activities Committee
ASHRAE Research Promotion Committee
ASHRAE Chapter Technology Transfer Committee
Young Engineers in ASHRAE Committee
Regional Historians
Assistant Regional Chairs
Board of Directors

FROM: Thomas E. Watson, PE

SUBJECT: PRESIDENTIAL AWARD OF EXCELLENCE (PAOE)

ASHRAE chapters are the backbone of this Society and play a central role in helping the Society achieve its goals. Through our collective efforts, ASHRAE chapters are a vital force in the built environment and a resource everywhere in the world.

My Presidential theme, “Broadening ASHRAE’s Horizons” emphasizes the role of ASHRAE members as leaders in the application of sustainable design and practices in our communities worldwide.

This marks the seventh consecutive year that the Presidential theme has focused on sustainability. This focus should be so ingrained in our lives that our mission “to serve humanity and promote a sustainable world”

inspires and guides our daily decisions.

Several new activities have been added to support the presidential theme and they focus on community involvement.

50 points for grassroots advocacy training for chapter officers and future leaders (minimum 1 hour of training) (100 points maximum)

50 points for establishing and maintaining a chapter grassroots advocacy committee with at least two members to promote ASHRAE with state, provincial, and local governments

50 points for establishing a Chapter Sustainability Committee that meets periodically that organizes at least two HVAC&R related sustainability activities per year

50 points for chapter publicity that includes issuing at least six (6) press releases or arranging one (1) or more TV appearances promoting the work of ASHRAE (150 points maximum)

500 points for chapter sponsored community sustainability project or event in conjunction with a non-profit organization (Note: ASHRAE provided Community Sustainability Project Tool Kit is available to assist.)

100 points for chapter sponsored community sustainability project publicity (outside of normal Chapter advertisements) that includes Print, Audio or Electronic media at a local, state, provincial, national or industry level promoting the work of ASHRAE and/or the local chapter (500 points maximum)

25 points for chapter officers or MP Chair promoting ASHRAE membership to local companies (e.g. reception, one/one meeting, company presentation) in order to increase their support in ASHRAE (150 points maximum)

25 points for each article (minimum 250 words) on a grassroots advocacy-related (i.e., state provincial, or local legislative or regulatory issue) published in a chapter newsletter or posted on a chapter website with copy sent to RVC (maximum of two articles per month) (300 points maximum)

There are six categories included in this year's PAOE: Chapter Operations, Chapter Technology Transfer, Historical, Membership Promotion, Research Promotion, and Student Activities. To achieve PAOE, the chapter must earn the minimum points in four of the following five categories: Chapter Operations, Chapter Technology Transfer, Membership Promotion, Research Promotion, and Student Activities. Please refer to the criteria specified in each of the categories for calculating the PAOE points. For additional information or clarification, check the PAOE Frequently Asked Questions (FAQ) section on the ASHRAE website. Please note that appropriate documentation should be kept by the Chapter to support PAOE point input, and that "chair" is defined as the individual listed in the Chapter Information Questionnaire (CIQ) on file with Society.

I appreciate your dedication, enthusiasm and hard work in improving our Society and providing value to our membership. I look forward to working with you during this Society year.



Mission Statement

ASHRAE will advance the arts and sciences of heating, ventilation, air conditioning, refrigeration and related human factors to serve the evolving needs of the public and ASHRAE members.

Vision Statement

ASHRAE

- ~ Will be the global leader in the arts and sciences of heading, ventilation, air conditioning & refrigeration.
- ~ Will be the foremost, authoritative, timely and responsive source of technical and educational information, standards and guidelines.
- ~ Will be the primary provider of opportunity for professional growth, recognizing and adapting to changing demographics, and embracing diversity.

Presidential Award of Excellence Totals

Presidential Award of Excellence (PAOE) is the point system ASHRAE Region and Society use to help track the Chapter's activities. The chapter gets points in the below categories for activities that we do throughout the year. The awards banner that you see at the meetings represents CVC's accomplishments over the years. Below are definitions of what some of those awards are. If you want to know more about PAOE check out the www.ashrae.org website and do a search for the 2006-2007 PAOE newsletter.

End of Year Awards Available to the Chapter:

PAOE: Minimum in five of the six categories

Special Citation: Minimum in 5 of the 6 categories with a minimum total of 4600 points

STAR: PAR in all categories

Honor Roll: PAOE for at least 4 consecutive years

High Honor Roll: STAR for at least 4 consecutive years

Premier: PAOE every year since the chapter's inception or since 1970; minimum of 4 years; chapter's first year is excluded

Sustainability Activities Award: A Chapter Sustainability Award in the form of a certificate is available for each chapter that obtains a total of at least 200 points from the items listed under Sustainability

Activities in the Chapter Operations category of PAOE. The Chapter with the highest PAOE Sustainability point total will receive a Regional award in the form of a glass plaque and a certificate. Level 1 = less than 100 members; Level 2 = 100-249, Level 3 = 250-449, Level 4 = 500 or more.

Category	PAR	2012 - 2013
Membership Promotion	800	275
Student Activities	500	1180
Technology Transfer	850	1400
Research & Promotion	1050	985
History	300	425
Chapter Operations	600	1335
Chapter TOTAL	4100	5600

2012-2013 BOARD OF GOVERNORS

Joshua Chiappone T: (518) 817-8669 joshua.j.chiappone@jci.com	Shawn LaBelle T: 802-857-5011shawn. ShawnL@amivt.com
Rachael Mascolino T: (802) 540-7846 rmascolino@veic.org	Mike Cook T: (802) 291-0911 mcook@arcmech.com
Dick Wilcox T: (802) 655-8805 dwilcox@vhv.com	

2012-2013 CHAPTER OFFICERS

President	Thomas Dacres, Jr., LEED AP BD+C (802) 655-8805 x 152 tom@d@vhv.com
President- Elect	Nathan Mascolino, PE, LEED AP (802) 861-6148 nathanm@vhv.com
Vice President	Robert J. Favali, LEED Green Associate (802) 764-2704 rfavali@dubois-king.com
Secretary	Robert Ward III, LEED AP (802) 861-6194 robw@vhv.com
Treasurer	Peter Bailey (802) 434-2278 pfbaily@deicontrols.com

COMMITTEE CHAIRPERSONS

Student Activities	Shawn LaBelle 802-857-5011 ShawnL@amivt.com
Membership	Joshua Chiappone (518) 817-8669 joshua.j.chiappone@jci.com
Research Promotion	Robert Ward III, LEED AP (802) 861-6194 robw@vhv.com
Technology Transfer	Nathan Mascolino, PE, LEED AP (802) 861-6148 nathanm@vhv.com
Refrigeration	Peter Bailey (802) 434-2278 pfbaily@deicontrols.com
Historian	Mike Cook (802) 291-0911 mcook@arcmech.com
Electronic Communications	Rachael Mascolino (802) 540-7846 rmascolino@veic.org
Newsletter Editor	Cara Gorman cara@ashraevt.org
2013 CRC	Tom Zoller (802) 864-3816 x2 TZoller@trane.com
2013 CRC Vice Chair	Steve Poole (802)861-6133 spoole@vhv.com

Subscription to the newsletter and membership questions should be directed to Joshua Chiappone (518) 817-8669 or joshua.j.chiappone@jci.com

Disclaimer Statement: Statements made in this publication are not expressions of the Society or of the Chapter and shall not be reproduced without special permission of the chapter.

Help your customers save on equipment costs today and energy costs for years to come.

Contact us today to find out more.



888-921-5990 | www.encyvermont.com

Raymond M. Keller, P.E., CEM

Energy Services Engineer
LEED AP

Vermont Gas Systems, Inc.

P.O. Box 467, Burlington, VT 05402-0467
85 Swift Street, So. Burlington, VT 05403
Tel: 802-951-0389
Fax: 802-863-8872
rkeller@vermontgas.com



Vermont Gas
CLEAN ENERGY. CLEAN AIR.

www.jwstevens.com

Cleaver-Brooks

Factory Authorized Sales, Parts, Service

Boilers
Burners
Controls
Energy Projects
Emissions Control
Pumps
Waste Water
Water Softeners



A Blake Group Company

Sales • Service • Parts

800-536-8833(24/7 Service) 518-482-4549 FAX

Robert J. Favali, LEED Green Assoc.
Director, Building Services



34 Blair Park Road - Suite 10
P. O. Box 1257
Williston, Vermont 05495

Phone: (802) 878-7661
Cell: (802) 922-6909
E-mail: rfavali@dubois-king.com
Website: www.dubois-king.com

- ENGINEERING
- PLANNING
- DEVELOPMENT
- MANAGEMENT



R. J. Murray Co., Inc.
H.V.A.C. Wholesale Distributor

Chuck Kabrehl
Vice President, Commercial Sales
ckabrehl@rjmurray.com
Direct Line: 518-690-4974 x106
Cell: 518-281-2461

7 Northway Lane
Latham, NY 12110
Phone: 518-690-4455
Fax: 518-690-4990

"Always A Better Value"

We Make Buildings...Great!



ADVANCED COMFORT SYSTEMS

12B Commerce Drive
Ballston Spa, NY 12020-3631
518-884-8444 ext 3410
518-884-8411 fax
518-424-5726 cell

harrisunger@advancedcomfortsys.com
www.advancedcomfortsys.com

Harris Unger
Sales Representative



Dodge Engineering & Controls, Inc.

Actuators, Control Valves, Dampers, Flow Sensors and Patented Hybrid Refrigeration Systems

Peter F. Bailey

Northeast Regional Sales Manager

Regional Office:
13 East Main Street
Richmond, VT 05477
PFBailey@DEIControls.com
Website: DEIControls.com

Tel. (802) 434-2278
Fax (802) 434-4150
Corporate Headquarters:
Toll free (877) DEI-CTRL
Fax: (978) 244-1422



Brian Sager

Vice President/Designer/LEED AP

bsager@arcmech.com
www.arcmech.com

603-443-6111 802-222-9255 603-444-3440
Lebanon, NH Bradford, VT Littleton, NH



James D. LaVallee

Director of Business Development

Direct 802.264.1158 Jim.LaVallee@vtmechanical.com
Fax 802.264.1109 www.vtmechanical.com
Mobile 802.324.3355



A Mechanical Company

Thomas F. Dacres, Jr. 16 Tigan St., Suite A, Winooski, VT 05404
 Design Engineer 802.655.8805 phone
 tomf@vhv.com ext. 152
 802.655.8809 fax

Tom Zoller PE
Account Manager



175 Leroy Road
 Williston VT 05495
 TEL 802 864 3816 TOLL-FREE 888 277 1497
 FAX 802 864 5093
 tzoller@trane.com
www.trane.com

Thomas Engineering Associates, PC



Glenn R Thomas
 PE, CxA, LEED AP
 Principal

HVAC, Plumbing, & Piping Systems Design
 Mechanical Systems Commissioning
 Complete MEP design available

PO Box 1420 glenn@tea-vt.com
 4429 Main St Tel: 802.583.1051
 Waitsfield, VT 05673 www.TEA-VT.com Cell: 802.343.4673

EST. 1970



THERMAL ENVIRONMENT SALES, INC.

11 SITTERLY ROAD • CLIFTON PARK • NEW YORK 12065

ERIK J. BRUHNS TEL (518) 373-1100
 VICE PRESIDENT FAX (518) 373-1800
 ENGINEERING SALES E-mail: ebruhs@teshvac.com

ENGV, Inc.

76 Bear Mountain Road
 Bolton, VT 05676
www.engvt.com

SERVICES

Process Engineering
 HVAC / Controls Engineering
 3D and BIM Modelling
 Commissioning
 Energy Studies & Analyses

INDUSTRIES

Semiconductor
 Pharmaceutical / Biotech
 Food & Beverage
 Manufacturing

MANUFACTURER'S REPRESENTATIVE/DISTRIBUTOR
 OF HEATING, VENTILATING
 AND AIR CONDITIONING PRODUCTS

JOHN P. WHITBREAD
Sales Engineer

BUCKLEY ASSOCIATES, INC.
 120 RAILROAD AVENUE
 ALBANY, NY 12205

TEL. (518) 438-7423 • FAX (518) 438-5527
 INTERNET: buckleyonline.com



HANOVER, MA NEWINGTON, CT MANCHESTER, NH



TECHNOLOGY PLUS

121 DRAHOS DRIVE
 ALTAMONT, NY 12009
WWW.TECHPLUSLLC.COM

BRIAN SEXTON
 EMAIL: BRIAN@TECHPLUSLLC.COM

OFFICE 518-664-0012
 FAX 518-664-5378
 CELL 518-320-2733

BOILERS • HYDRONICS • STEAM SPECIALTIES

Hallam/ICS 38 Eastwood Dr., Suite 200
So. Burlington, VT 05403

Engineering
Control Systems Integration
Commissioning

TEL | 802.658.4891
FAX | 802.658.1457
TOLL FREE | 800.287.0800

info@Hallam-ICS.com

www.Hallam-ICS.com

James Harrington PE
Engineering Manager

P: 802-264-1232
C: 802-238-1284
jmharrington@near.com

 **New England
Air Systems**

Complete Mechanical Systems & Service

43 Krupp Drive PO Box 525 Williston Vermont 05495



JOHN F. GROUT

10 Benning Street, #168
W. Lebanon, NH 03784
Email: jgrou@victaulic.com

Cell: 508/878-9155
Fax: 610/923-3464



Dan Connelly

5615 BUSINESS AVE. • CICERO, NY 13039

Direct (315) 458-2877
Main (315) 458-2875
Fax (315) 458-2187
Mobile (315) 529-3371
Email dconnelly@rkistler.com
www.rkistler.com

- PRECISION AIR CONDITIONING
- PRECISION POWER CONDITIONING
- EMERGENCY GENERATORS
- HUMIDIFICATION / DEHUMIDIFICATION
- FUME HOOD CONTROLS
- GREEN HVAC PRODUCTS



Alan E. Ouellet
Executive Vice President

15 Adams Street
Burlington, MA 01803-4916
Phone (781) 272-0060 X225
Fax No. (781) 272-0227

Cell Phone (781) 254-2442
E-MAIL aouellet@filtersales.com
WEB SITE filtersales.com

FILTRATION SPECIALISTS



R.F. Peck CO., INC.
22 COMPUTER DRIVE WEST
ALBANY, NY 12205

Phone (518) 869-3541
Fax (518) 869-5718
Cell (518) 469-7072
Email: mbronder@rfpeck.com

Mike Bronder
Sales Engineer

Manufacturer's Representatives for
Heating, Ventilating and Air Conditioning Equipment
— Visit our Web Page @ www.rfpeck.com —



LEONARD PATTISON, C.E.M.
President
lpattison@controltechvt.com

121 Park Ave Suite 10
Williston, VT 05495
DID: (802) 764-2223
Cell: (802) 999-4282
Phone: (802) 764-2200
Fax: (802) 764-2299

www.controltechinc.com

Other Offices
Manchester, NH
Great River, NY
Woburn, MA
Anaheim, CA



Joshua Chiappone
Systems Sales Engineer
Building Efficiency

116 Railroad Avenue, Albany, NY 12205 USA
Tel 518 451 2709 Cellular 518 817 8669
Fax 518 451 2701 joshua.j.chiappone@jci.com
www.johnsoncontrols.com

Printed on material from well-managed forests and post-consumer fiber; manufactured chlorine-free.